

Dandy Dock™

PWC Drive on Instructions

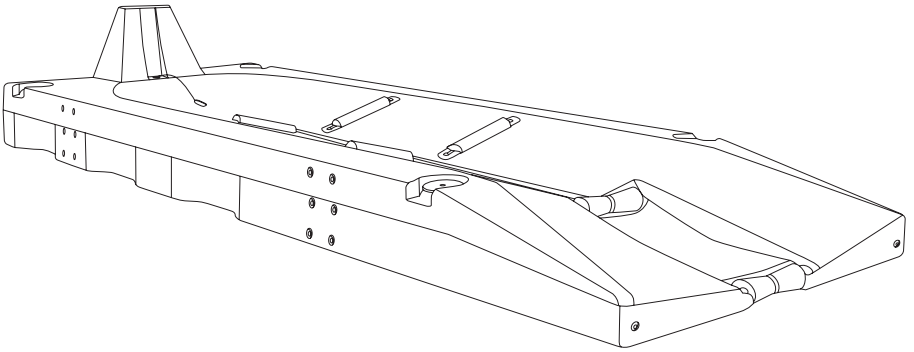

Table of Contents

www.dandydocks.com

1-800-825-7719

Dandy Dock™

Fixed Dock Attachment	1
Floating Dock Attachment	2
Side by Side Connecting Kit	3
2000 Series Attachment	4
2000 Series Offset Attachment	5
Winch	8

Some products in this instruction book are protected by one or more of the following patents.
USA patents: 6,073,572; 5,281,055; 7,481,175; and 6,179,525 B1
Canadian patents: 2,308,617; 2,328,022

Fixed Dock Attachment

www.dandydocks.com

1-800-825-7719

Tools Needed

- (1) 3/4" Wrench
 - (2) 9/16" Wrenches
- Not available in metric*

Needed Items

pipe size 2" sch 40 pipe or max dia of 2.375" (50 Dn mm sch 40)

Step 1

Install roller closest to the Roller Bracket. Secure with the washers and cotter pins.

Step 2

Determine location of port installation (front or side). Attach the two Roller Brackets to the front or side of the port. Use the 1/2" (13 mm) bolts and lock washers (25ft/lbs)(3.46 kg/m).

Step 3

On a fixed dock it is recommended to get a pipe long enough to drive into the ground, in some cases this is all that is needed to hold the port in place. If you have a very secure fixed dock you can mount the pipe to the dock but if the dock is not of the best integrity it is not recommended because it will work the dock loose if you are in a high wake area. It is recommended that you drive the pipe in the ground and mount it to a fixed dock if applicable. Note: pipe size 2" sch 40 pipe or max dia of 2.375". (50 Dn mm sch 40) Roller Bracket on center 4' (1.2192 m) front & 6' (1.8288 m)side.

Step 4

(a)Float port up to pipe and install front rollers. (b)Leave cotter pins and washers off when inserting roller axle into the roller. Next secure roller with cotter pins and washers.

1

Instructions for:

Fixed Dock Attachment Kit
(4-2118)

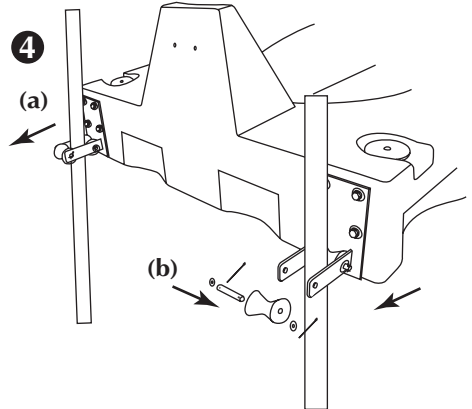
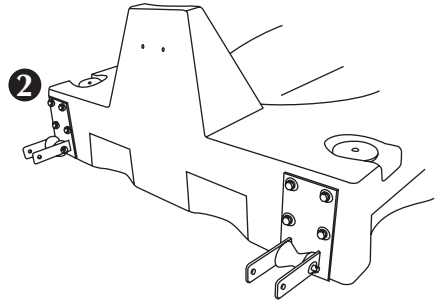
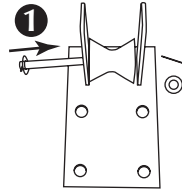

Floating Dock Attachment

www.dandydocks.com

1-800-825-7719

Tools Needed

- (1) Drill - 1/4" (6.5 mm) & 7/16" (11 mm) drill bit
- (1) 3/4" (18 mm) Wrench
- (2) 9/16" Wrenches *Not available in metric*

Step 1

Center Pivot Pin in Small Hinge Bracket and drill thru the Pivot Pin with 1/4" (6.5 mm).

Step 2

Attach the two Small Hinge Brackets to the front of the port. Turn the hinge part up or down depending on how high your dock is off the water. Use the 1/2" (12 mm) bolt and lock washer (25ft/lbs)(3.46 kg/m)

Step 3

(a) Attach one Large Hinge Bracket with Pivot Pin to the Small Hinge Bracket. Then align the Large Hinge Bracket with dock to determine bolt hole location. If you are on a very high dock there is an extension plate available to accommodate your situation. You may want to put your PWC on the port at this time to see how it makes the float set in the water, if the entrance end of the port is high with the craft on it you will want to raise the front of the port to give a slight down hill appearance for easy roll off. Remember, if it rolls off too hard the mount is too low, rolls off too easy you are too high. (b) Mark holes. Drill with 7/16" (11 mm) bit. 3/8" (9 mm) bolts, washers and lock washer not supplied.

Recommended 4 to 6 mounting holes. Mount the Large Port Bracket to the dock and attach port hinge and secure with Pivot Pin. Repeat on next bracket.

Note: If mounting port to wooden floating dock use 3/8" (9 mm) Lag Bolts (screw based)

Instructions for:

Floating Dock (4-2219)

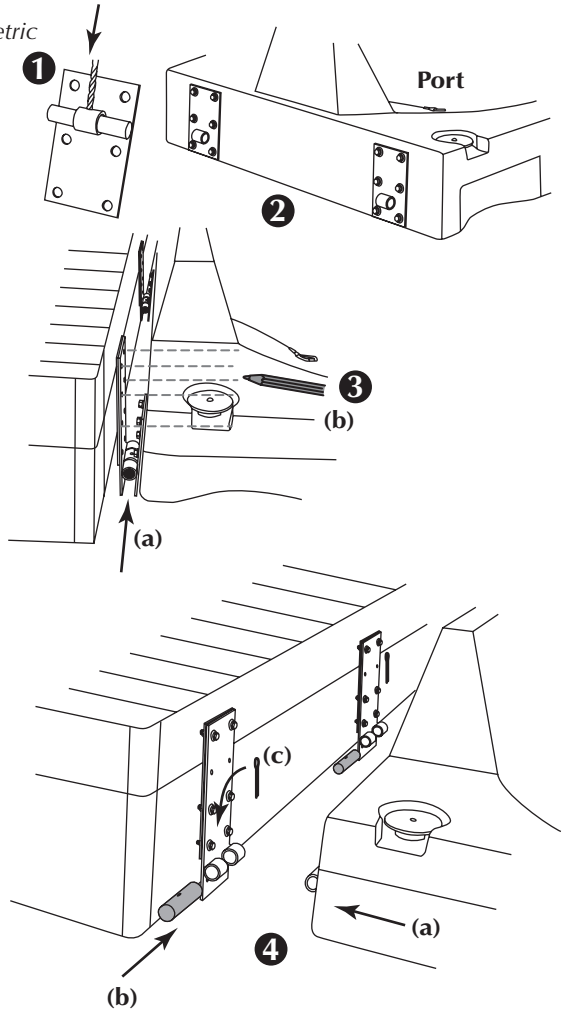

Step 4

- (a) Align hinge point of port and dock.
- (b) Insert Pivot Pin with the 1/4" 6.5 mm hole up.
- (c) Secure Pivot Pin with cotter pin.

Side by Side Attachment

www.dandydocks.com

1-800-825-7719

Tools Needed

- (1) 3/4" Wrench
- (1) 5/16" Allen Wrench
- Not available in metric*

Step 1

Align front of ports. Attach plate with eight holes to top two rows of inserts. Use the 1/2" bolt and lock washer (25ft/lbs)(3.46 kg/m).

Step 2

Attach two hole plate inserts. Use the 1/2" button head bolt, lock washer and washer (25ft/lbs)(3.46 kg/m).
Note: Rear connection is made to swivel when driving PWC on to the port.

Instructions for:

Side by Side Kit (4-2150)

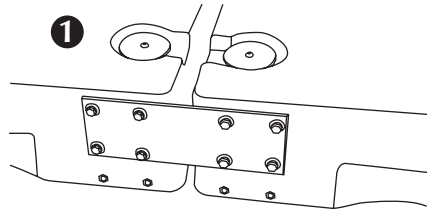

Port Front

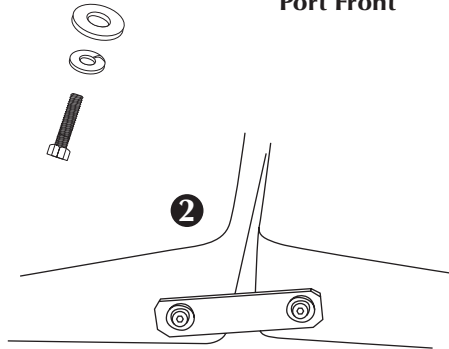

Port Rear

Connect-A-Dock 2000 Series Attachment

www.dandydocks.com

1-877-742-3071

Tools Needed

- (1) 3/4" Wrench
- (2) 9/16" Wrenches
- Not available in metric*

Instructions for:

2000 Series Attachment Kit
(4-2190)

Step 1

Determine port location (Front or Side). Insert Metal Pole Connectors into float section connector slots. Tighten all bolts in the dock using 25 lbs/ft (3.46 kg/m) of torque.

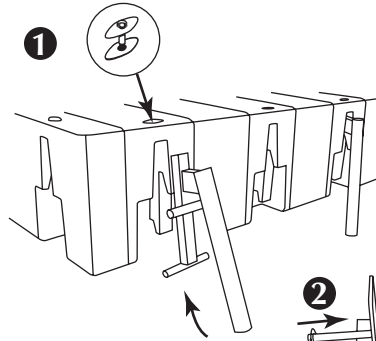

Step 2

Install roller closest to the Roller Bracket. Secure with the washers and cotter pins.

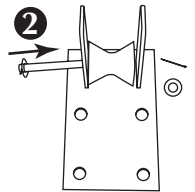

Step 3

Attach the two Roller Brackets to the front or side of the port. Use the 1/2" bolts and lock washers (25ft/lbs)(3.46 kg/m).

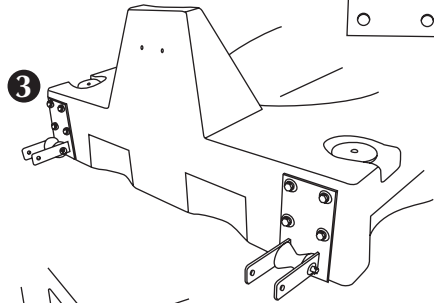

Step 4

(a) Float port up to Roller Pole Connectors. (b) Install front rollers. Leave cotter pins and washers off when inserting roller axle into the roller. Next secure roller with cotter pins and washers.

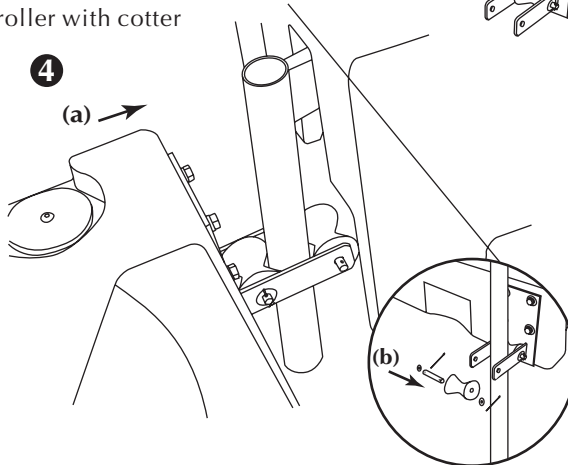

DandyDock Dandy Dock™ Warranty — USA & Canada

Dandy Dock Inc. warrants to the original owner all polyethylene plastic components for five (5) years from date of purchase to be free of defects in material and workmanship. For a copy of the Dandy Dock complete warranty call Dandy Dock.

DandyDock Dandy Dock™ Warranty — International

Dandy Dock Inc. warrants to the original owner all polyethylene plastic components for two (2) years [one (1) year for commercial use] from date of purchase to be free of defects in material and workmanship. All other accessories have a one (1) year limited warranty. For a copy of the Dandy Dock complete warranty call Dandy Dock.

Should you have a warranty claim, we may require that you provide a photograph or, in some cases, return the Dandy Dock part to the place of purchase. In order for warranty to be valid, original sales receipt must accompany warranty claim. NOTE: Shipping costs are not included in warranty.

NOTE: All plastic has an inherent tendency to create static electricity. If you have a concern, contact Dandy Dock.

1501 Owner Avenue, Atlantic, IA 50022 USA
1-800-825-7719 (toll free U.S.A. only) 1-712-243-2430

Please call us with your questions and comments